

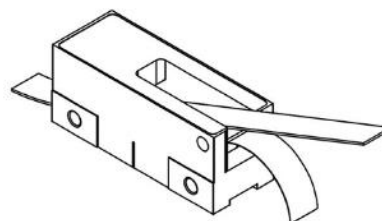

**Readhead mounting and alignment**

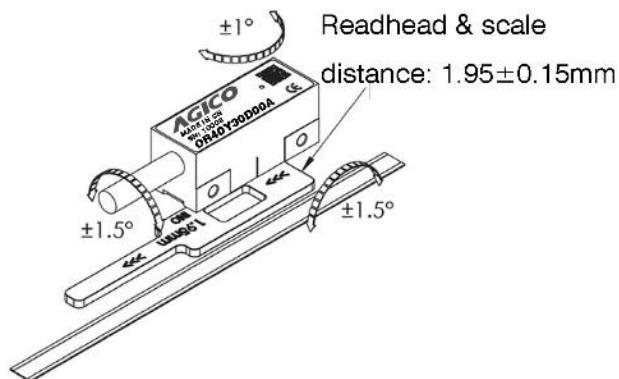

Scale applicator

**Digital / Analogue output signals**

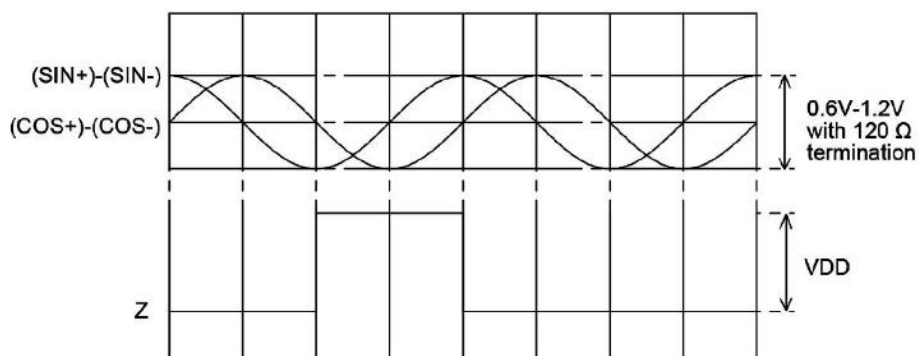
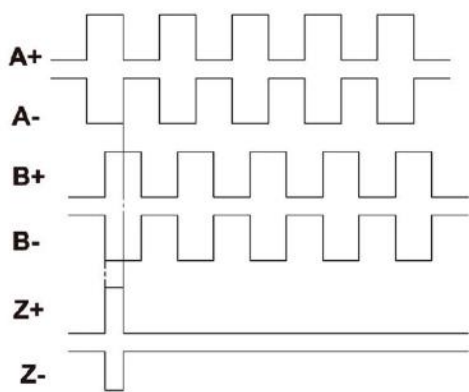

**Recommended signal termination**

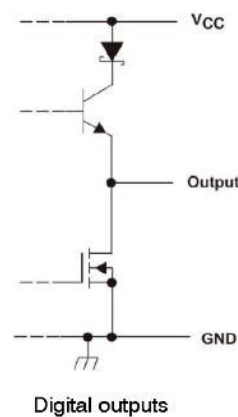
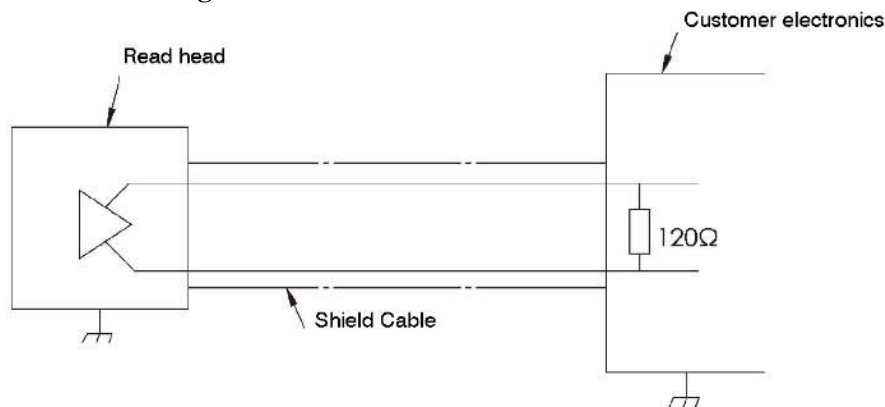

**Limit / Alarm output signals**

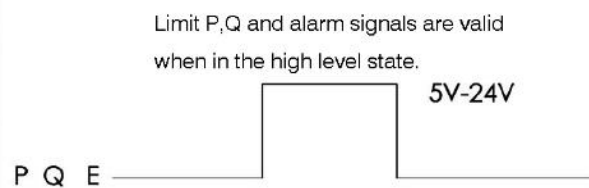
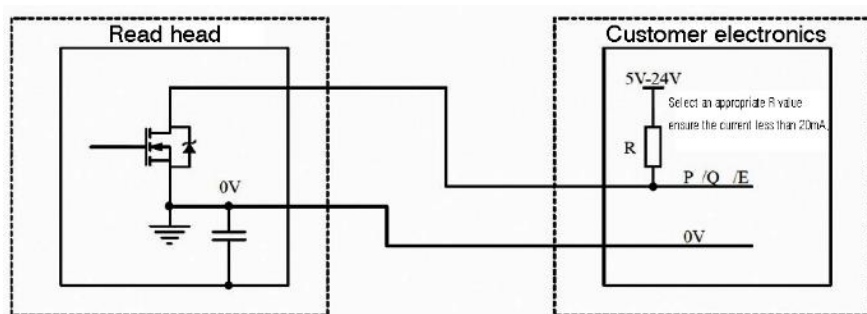

**Linear scale**

Feature	Technical Data	Additional information
Linear Scales	OS40	
Pitch	40mm	
Form (height × width)	0.3 × 6mm; 0.3 × 8mm	
Accuracy	±6 μm/m	
Linearity accuracy	±3 μm/m	
Maximum length	50m	
Coefficient of thermal expansion	10.1±0.2 μm/m/°C	(at 20 °C)
Mass	15g/m	

**Analogue outputs**

Function	Signal	Colour	9-way D-type	15-way D-type
Power	5V	Red	5	7
	0V	Black	1	2
Incremental	SIN+	White	2	14
	SIN-	Grey	6	6
	COS+	Blue	4	13
	COS-	Purple	8	5
Reference mark	Index+	Brown	3	12
	Index-	Orange	7	4
Shield	In	Silver	9	15
	Out	Screen	Case	Case

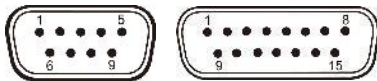

**Digital output**

Function	Signal	Colour	9-way D-type	15-way D-type
Power	VCC	Red	5	4
	GND	Black	1	12
Incremental	A+	White	2	9
	A-	Grey	6	1
	B+	Blue	4	10
	B-	Purple	8	2
Reference mark	Z+	Brown	3	3
	Z-	Orange	7	11
Limits	P	Yellow	-	15
	Q	Green	-	4
Alarm	E	Pale Green	-	12
Shield		Screen	Case	Case

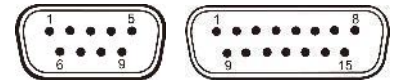

**Readhead part numbers**

**OR40X30D00A**

**Series**

**Pitch:** 40um

**Resolution:**

- O : 10nm (Max Speed:0.3m/s)
- I : 20nm (Max Speed:0.6m/s)
- K : 40nm (Max Speed:1.1m/s)
- H : 50nm (Max Speed:1.5m/s)
- Y : 0.1um (Max Speed:3m/s)
- W : 0.2um (Max Speed:6m/s)
- Z : 0.5um (Max Speed:15m/s)
- X : 1um (Max Speed:18m/s)
- D : 5um (Max Speed:18m/s)
- A : 1VPP **Analogue outputs**

**L: Limit magnet A: Customided**

**D00: Open cable ends**  
**D09: 9-way D-type**  
**D15: 15-way D-type**

**Cable length:**

- 03: 0.3m    05: 0.5m
- 10: 1.0m    15: 1.5m
- 30: 3.0m    50: 5.0m
- 100: 10m
- Customized lengths

**Linear scale part numbers \_ OS40 series**

Feature	Order data	Specifications	Additional information
Width (mm)	06	A	
	08		
Scale length (mm)	300	B	0.3m
	900		0.9m
	3000		3m
	...		Max. 40m
Adhesive	-	C	With adhesive
	E		Without adhesive

**Optional parts**

Tools	Part NO
Reference mark magnet	IND140712
P,Q limit magnet	LIM1050413
Scale applicator	OS40-MT06
End clamp	602EP

